

MDS SERIES

**HIGH-PERFORMANCE SUSPENSION
DESIGNED FOR MEDIUM-DUTY TRUCKS.**

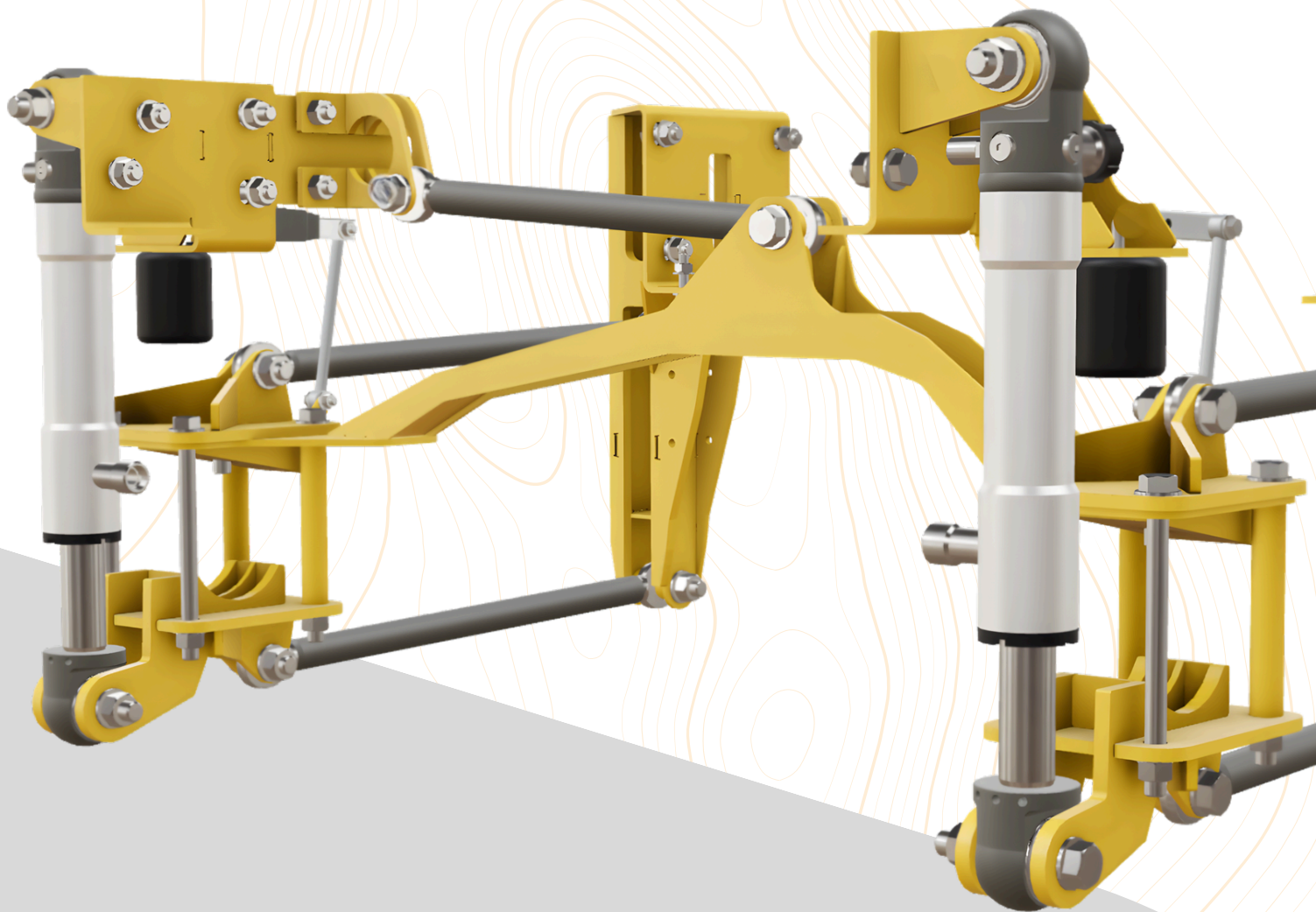

1(800)423-5347 SIMARDSUSPENSIONS.COM SALES@SIMARDSUSPENSIONS.COM

1935 - 2025 | 90 YEARS OF INNOVATIONS

DESIGNED FOR THE MOST DEMANDING APPLICATIONS such as emergency vehicles, service units, offroad rescue trucks, military vehicles, buses, bucket trucks, snow removal, towing, and expedition trucks. The MDS Series offers more stability, better road control and consistent performance under heavy use, for more efficient and reliable trucks every day.

PAYLOAD CAPACITY

Weighing up to 300 lbs less than the aftermarket equivalent, it is lighter, frees up payload and provides more headroom for equipment, turning every pound saved into real operational capability.

MAINTENANCE AND OPERATION

Designed for simple and predictable maintenance, reducing downtime and maximizing truck operating time.

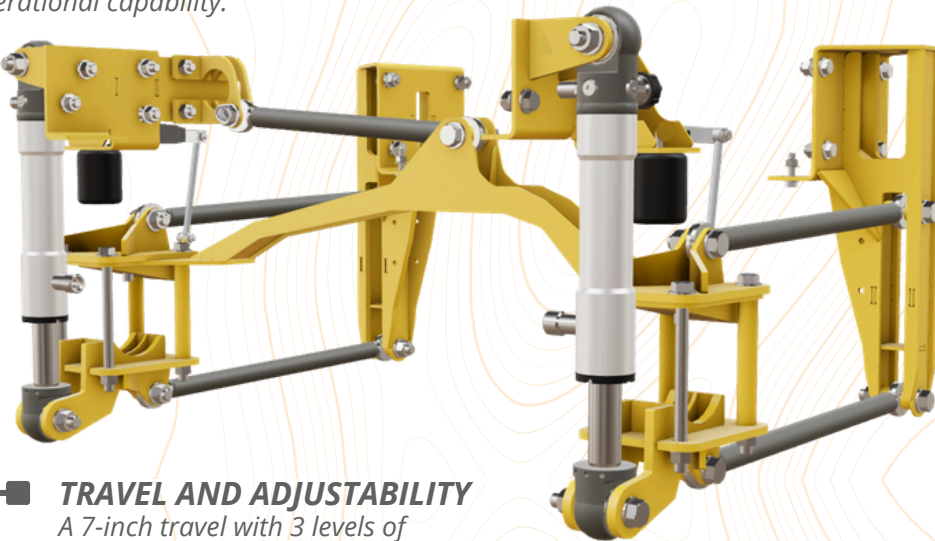

TRAVEL AND ADJUSTABILITY

A 7-inch travel with 3 levels of adjustment depending on the configuration, terrain type, and road conditions.

PERFORMANCE AND STABILITY

Superior stability that keeps the truck under control, reduces driver fatigue and secures equipment when conditions become demanding.

SPECIFICATIONS

SUSPENSION TYPE	Hydropneumatic, front and rear
PAYLOAD CAPACITY	FRT : 8000 / 12000 lbs (3628 / 5445 kg) RR : 12000 / 16000 / 18000 / 21 000 lbs (5445 / 7250 / 8180 / 9525 kg)
TRAVEL	180mm (7 inches)
ADJUSTABILITY	Suspension drop capability

TRUCK CLASSES	4 / 5 / 6 / 7
WEIGHT	450 lbs (204 kg)
TECHNOLOGY	OTA (Over-The-Air) diagnostic capability *
WARRANTY	100 000 km (62 150 miles) / 1 year
APPLICATION	emergency vehicles, service units, offroad rescue trucks, buses, etc.

*OTA hardware required



LET'S BRING YOUR NEXT PROJECT TO LIFE

Configurations available for all vocational applications.

